

Tech Spec

Date: 31 January 2022

Earlier versions should be destroyed. Printed versions may be out of date.
Information believed correct at time of writing. Please contact us for any updates.

Important

We recommend you refer to this document and the referenced diagrams, prior to using the venue. It contains useful information about our systems and equipment which will help with design, preparation, get-in, tech, operation and get-out of your show.

It is also a useful reference in the event of any issues.

Contact Info

Jermyn Street Theatre
16b Jermyn Street
London
SW1Y 6ST

There is no off-street parking or loading bay.
On street parking and loading is controlled by Westminster.

Web: www.jermynstreettheatre.co.uk
Email: info@jermynstreettheatre.co.uk
Telephone: 020 7434 1443

Contents

| | |
|---|----|
| Tech Spec | 1 |
| Important | 1 |
| Contact Info | 1 |
| Venue Specification..... | 3 |
| Layout..... | 3 |
| Productions | 3 |
| Technical Inventory | 4 |
| Lighting..... | 4 |
| Video | 4 |
| Sound..... | 5 |
| Other Equipment..... | 6 |
| Consumables..... | 6 |
| Tools | 6 |
| Lighting | 7 |
| Lighting Desk | 7 |
| Lanterns | 7 |
| Lamps | 7 |
| Gels and Gobos..... | 7 |
| Dimmers, Hot Power and Load Lamps..... | 8 |
| DMX | 8 |
| House Lights | 8 |
| Bar Sign | 9 |
| Working Lights..... | 9 |
| Desk Lamps | 9 |
| Emergency Lights..... | 9 |
| Projector..... | 9 |
| CCTV..... | 9 |
| Use of Smoke or Haze | 9 |
| Air Conditioning | 9 |
| Network | 10 |
| Internet..... | 10 |
| Main Network..... | 10 |
| Tech Network | 10 |
| Power..... | 11 |
| On Stage Power | 11 |
| Production Desks..... | 11 |
| Sound..... | 12 |
| Playback: Mac Mini, QLab, Yamaha Mixer..... | 12 |
| Sound Default Configuration..... | 12 |
| Audio Patch | 13 |
| Speakers and Patch | 13 |
| Tie Lines | 14 |
| Show Relay & Paging..... | 14 |
| Hearing Loop..... | 14 |
| Intercom (Ring)..... | 15 |
| Live Music | 15 |
| Piano | 15 |
| Foyer Sound System | 15 |
| Video | 15 |
| Appendix 1 – Power Distribution..... | 16 |
| Office..... | 16 |
| Control Box | 16 |
| Dimmer Room | 16 |
| Dressing Room 2 | 17 |

Venue Specification

We have separate Venue Users Guide and Design Guidelines available on Dropbox [here](#), along with diagrams, manuals and other information.

Layout

- Raked seating for 70 with 5 rows facing, 2 rows on stage-left side.
- Flat floor-level stage with lighting grid.
- Stage space is 8 metres long x 4 metres deep x 3.5 metres high (to grid).
- Where measurements are critical, they should be checked on site.
- Refer to the **separate Seating Plan and Grid Plan documents** on DropBox [here](#).
- There are 2 dressing rooms with fridges, microwaves, kettles. Iron and ironing board available.

- The venue is situated in the basement, accessible from street level via a flight of stairs to:
 - Foyer
 - Box Office
 - Office
- Then there is a further small flight of stairs to:
 - Auditorium, with Fire Exit
 - Bar servery
 - Stage
 - Control Box
 - Backstage corridor
 - Toilets x 3
 - Dimmer Room
 - Piano Store
- Backstage facilities are located in the sub-basement, via a curved flight of stairs:
 - Production/Stage Managers Room / Dressing Room A
 - Room 0 – *The Folly* – Office and store
 - Dressing Room 1
 - Dressing Room 2
 - Workshop and Tech Store, with Fire Exit to staircase to street level
- There is a separate staircase to a street level Fire Exit, also typically used for load-in and load-out.
- There is no lift to any level.

Productions

Typically, we host a **main show** with a run of several weeks with a number of **ad-hoc events** taking place between main show performances, such as daytimes or Sunday evenings. These ad-hoc events can include rehearsed readings, showcases, touring shows etc. which take place ‘on top’ of the main show stage, set, technical rig and backstage arrangements.

Main shows will have priority on use and configuration of theatre and equipment.

Ad-hoc events during a main show run will be restricted from making changes to the main show configuration, subject to arrangements with management.

Technical Inventory

All equipment is for appropriate use by competent personnel only, who should check/test it before use. Do not use any damaged or faulty items, and report any problems to us.

Please do not modify our equipment or cables etc. without our permission. Please replace covers when equipment is not in use and overnight.

Please check with us as some equipment may be out for repair. Technical documents for most equipment are available in soft copy on DropBox [here](#).

All our equipment is registered and covertly security marked, with visible markings in green paint or tape. Some equipment is secured with locks – access is available only to authorised users.

If you wish to bring your own or hired equipment you must agree this with us in advance, and all equipment must have a valid safety test.

Please provide any tools and sufficient consumables you need for your production. Bring any PPE you need.

Lighting

| Qty | Control | Notes |
|-----|--|---|
| 1 | ETC Ion Xe desk (2048 channel) | With single display, optional 20 Fader Wing and Doremidi Hub-3 MIDI |
| 3 | Transcension HS2 DMX and Powercon splitter | 2-way splitter for grid mounting |
| | Dimmers | |
| 5 | Zero88 Betapack with 15A connectors | 30 channels of 10A max each (DMX 1 thru 30) |
| | Patch | |
| 72 | Patchable circuits using 15A connectors | To grid or floor 15A sockets |
| 18 | Hard power sockets using 15A connectors | 12 switchable circuits |
| 12 | Load lamps in an array using 15A connectors | For ballasting LED loads |
| | Lanterns | with 15A connectors unless noted |
| 10 | ETC ColorSource LED Par 14.5° (DMX) | LED 89w (with Powercon connectors) |
| 2 | Martin MAC Aura (DMX) | |
| 4 | Vision 1200W Fresnel 45/80° | 1.2kw T29 |
| 11 | Vision 650W Fresnel 45/80° | 650w T27/T26 |
| 3 | Quartet F Fresnel 10/40° | 650w T27/T26 |
| 10 | Vision PC 45/80° | 650w T27/T26 |
| 3 | Vision Profile Wide 23/40° | 650w T27/T26 |
| 3 | Vision Profile Narrow 14/30° | 650w T27/T26 |
| 8 | Source4 Junior Zoom 25/50° | 575w HPL575 |
| 2 | Source4 Par Lens MFL 21° x 34° | 575w HPL575 |
| 2 | Patt 743 Fresnel 8/60° | 1.2kw T29 |
| | Other | |
| 1 | Hitachi LCD Projector CPX1 (VGA) | With remote and mounting bracket. No screen. |
| 1 | Martin Atomic 3000 DMX Strobe | |
| | House lighting | |
| | Via separate dimmer by DMX (501 thru 504) and/or manual control panels | |
| | RGBW LED bar sign by DMX (506 thru 509) | |

Video

For video recording, playback and streaming please contact us.

Sound

| Qty | Playback | Notes |
|--------------------|--|--|
| 1 | Mac Mini (Model : A1347Late 2014 Macmini7,1) | With mouse, keyboard, display. Intel Core i5, 2core, 1.4GHz 4GbRAM 500Gb HDD Intel HD Graphics 5000 Gigabit Ethernet Wi-Fi Bluetooth 4.0 4x USB-A 3.0 2x Thunderbolt HDMI |
| 1 | QLab V4 | With Pro Audio bundle (& free video and lighting) Additional licensing can be arranged. |
| 1 | Yamaha 01v96i digital mixer | Also acts as QLab audio/MIDI interface via USB |
| 1 | Yamaha Studio Manager software | |
| 1 | Yamaha SPX990 effects unit | Two channels, rack mounted. |
| 1 | Sony CD Player | No remote |
| 1 | Behringer Ultra-DI active DI box | Uses 9v battery. Portable. |
| 1 | Behringer Ultrapatch Pro PX3000 patch | For routing audio, with default patch. Rack mounted. |
| Amps | | |
| 3 | Carver pm700 two-channel amps 225w@8ohm or 350w@4ohm | Rack mounted |
| 1 | Lepy LP-2024A+ two-channel amp 20w RMS 4-8ohm | Portable. With 12v DC power supply |
| Speakers | | |
| 2 | Meyer UPM-1P Powered | Hung in grid as Mains |
| 6 | Martin EM15 75w/15ohm | Four fixed as Fills. 2 in Tech Store |
| 1 | Martin EM150 400w/4ohm | Fixed under steps as Bass sub |
| 6 | JBL Control One 50w/8ohm | Four fixed as Rear Surrounds. 2 in Tech Store |
| 2 | eAudio B406A 80w (Peak not RMS)/8ohm | For spot audio with Lepy amp |
| 1 | Speakon patch panel | For routing amps to passive speakers |
| Microphones | | |
| 1 | Shure SM58 dynamic mic | Unswitched |
| 2 | Shure SM58 dynamic mic | Switched – one rigged as show relay mic |
| 2 | Shure PG58 dynamic mic | Switched |
| 3 | Shure SM57 dynamic mic | Unswitched |
| 4 pr | Behringer C-4 paired condenser mic | Total of 8 mics in 4 matched pairs |
| 4 ch | Sennheiser ew100 G4 radio mic system | 4 x EM100 G4 Receiver Racked with 2 antennas and distribution amp |
| 4 | Sennheiser ew100 G4 radio mic kits | SK100 Transmitter bodypack (2xAA battery) |
| 2 | Sennheiser ew100 G4 ENG radio mic kits | SK100 G4 Transmitter bodypack (2xAA battery) SKP100 G4 plug-on transmitter (2xAA battery) EK100 G4 Camera Receiver (2xAA battery) |
| 1 | Sennheiser ew100 G1 radio mic system (838-870MHz) | SK100 G1 Transmitter bodypack (2xAA battery) EM100 G1 Receiver |
| 4 | Mic stand – boom | |
| 4 | Mic stand | |
| 1 | Mic stand – round base | |
| Musical | | |
| 1 | Piano – Kawai upright with stool | Stored in Piano Store |
| 1 | RAT stand with light | |
| 2 | Music stand | Stored in Piano Store |
| 1 | Keyboard stand | Stored in Piano Store |

Other Equipment

| | Notes |
|-------------------------------------|-----------------------------------|
| Ladders (medium & high) | Stored in Dimmer Room |
| Stage Weights | Stored in Dimmer Room |
| Audio Cables and Adaptors | Stored in Control Box |
| Speaker Cables and Adaptors | Stored in Control Box |
| DMX Cables and Adaptors | Stored in Control Box |
| Power Cables, Adaptors and Grellcos | Stored in Dimmer Room |
| Safety bonds | On lanterns; spares in Tech Store |
| Gel frames | On lanterns; spares in Tech Store |
| Barn doors | On lanterns; spares in Tech Store |
| Gobo holders and Irises | Stored in Tech Store |
| Toolchest (see below) | Stored in Dimmer Room |

Consumables

| | Notes |
|---|--|
| Gobos (limited stock – see below) | Stored in Tech Store. Bring what you need. |
| Spare lamps (for stage lanterns – see below) | Stored in Control Box (overflow in Tech Store) |
| Spare bulbs (desk lamps and practical lights) | Stored in Control Box (overflow in Tech Store) |
| Spare bulbs (front of house and domestic) | Ask General Manager |
| Spare fuses (dimmers: 10A 6.3mmx32mm Fast) | Stored in Dimmer Room |
| Spare fuses (domestic) | Stored in Control Box |
| Spare batteries | No stock held. Bring what you need |
| Spare cable and connectors (limited stock) | Stored in Tech Store |
| Gel (limited stock – see below) | Stored in Tech Store. Bring what you need. |
| Tape (limited stock) | Stored in Control Box. Bring what you need. |

Please provide sufficient consumables for your production.

Tools

You should bring the tools you will need for your specific purposes, especially for get-in and get-out.

There is a toolchest with a limited set of tools available for supplementary use during get-in, get-out and for running repairs. Please take good care of these tools, and return them to the correct drawer of the tool chest between uses. Check for any damage before use, do not use any damaged items, and report any problems to us.

If any tools are lost or damaged, they won't be replaced unless paid for by the show.

Lighting

We have a standard default lighting control configuration as described below. Refer also to the indicated **diagrams**.

If agreed in advance with us, you may re-configure the lighting grid and program the lighting desk to suit your show. If you wish to bring your own or hired equipment you must agree this with us in advance, and all equipment must have a valid safety test. A grid load test certificate is available on request.

Be aware that at your get-in the previous show may left the system in an unknown configuration so you are advised to check and reset the system configuration as necessary. In particular check the QLab and Mixer configurations and patching.

Main shows will have priority on lighting configuration. Leave a lighting plan/diagram/description of your show's configuration in the Control Box.

Ad-hoc events during a main show run will have to make use of the lighting configuration fixed for the current show. In these cases, do not move, refocus or re-patch the fixed configuration lanterns. Do not alter the main show program in the lighting desk (but you can create your own separate program).

When handling lanterns remember they contain fragile glass lamps (bulbs) and lenses. Do not drop or bash them. Do not move lanterns while turned on or still hot as this will break the lamp filament.

You should return the lighting to an agreed configuration at your final get-out.

Lighting Desk

Each production is responsible for programming the lighting desk for their own show.

When programming the lighting desk for a **main show** run, please also program a sub-master on the desk, set up to provide an as good as possible general cover of lighting for use by other users between your sessions, e.g. ad-hoc events, rehearsals etc.

A USB MIDI interface is available for communication with the sound system.

Please note your configuration and save your program in the desk, taking a backup on USB drive (please bring your own). Other users may use the system between your sessions and while they should not alter your programming, it's better to play safe!

Please do not update the lighting desk software or system configuration without our permission.

The lighting desk is secured by "Kensington" cable locks in the Control Box. If it is necessary to relocate the desk to a production desk, you will need to unlock and resecure to the production desk. Codes are available to authorised users.

Lanterns

All our lanterns are fitted with clamps and bonds. Lanterns which use them have a gel frame and barn doors fitted. They should be left like this after your final get-out.

Spare gel frames are available for some lantern types. There is a recent inventory available in soft copy on our DropBox [here](#).

We have a limited stock of gobo holders and irises. There is a recent inventory available in soft copy on our DropBox [here](#).

Lamps

We keep a stock of spare lamps for our lanterns, and bulbs for desk lights, practicals, and general front of house and domestic lighting. There is a recent inventory available in soft copy on DropBox [here](#). We have converted to LED lamps for lighting other than theatre lanterns. Please bring your own lamps and spares for any equipment or practicals you bring.

Gels and Gobos

Lighting designers are advised to obtain their own lighting gels and gobos.

We do not keep a stock of gels, only those left behind by other users which you may use. These are filed by colour in the Tech Store, and ideally will have the gel number marked on them by whoever left them (if you leave some behind, please label them).

Similarly, we only have those gobos left by other shows which you may use. There is a recent inventory available in soft copy on our DropBox [here](#).

Dimmers, Hot Power and Load Lamps

Our dimmers and hot power are located in the dimmer room, with an adjacent patch panel connecting to sockets around the venue.

If using LED lamps with dimmers, additional loads may be required. There is a load lamp array located adjacent to the dimmers. It has a range of incandescent bulbs which can be patched to dimmers in parallel with the LED load. The wire cage protecting the bulbs can be unlatched at the two sides and swings down to allow bulbs to be changed.

DMX

There are two DMX universes (1 and 2) cabled with 5-pin XLR connectors to the corresponding universe on the lighting desk. If you bring any 3-pin devices you will need to bring your own adapters.

Universe 1 (colour coded Yellow) runs from Control Box to Dimmer Room then Bar Sign. DMX channels on Universe 1 are allocated as follows:

| | |
|---------------|--|
| 1 thru 36: | Dimmer channels 1 thru 36 |
| 501 thru 504: | House Light dimmer channels 1 thru 4 (see below) |
| 506 thru 509: | Bar sign (see below) |

Universe 2 (colour coded Brown) runs from Control Box via loop-in points around all four sides of the Grid and is terminated in the Grid at DSR.

Specific fixtures are labelled with their default DMX address ranges starting as follows. In the unlikely event they need to be changed, return them to the default at final get-out.

| | |
|-----------------------------|--|
| 50, 60, 70, 80 ... 130, 140 | 10 off ETC ColorSource PAR (5-channel mode) |
| 150, 180 | Martin MAC Aura (14 or 25 channel modes) |
| 400 | Martin Atomic 3000 DMX Strobe (4-channel mode) |

House Lights

Our House Lights have a dedicated 4-channel dimmer, operated manually via control panels in the Control Box and Box Office, or by the lighting desk using DMX. The majority of House Lights have LED bulbs.

One House Light channel controls a socket near the lighting patch typically used for an illuminated Toilets sign indicating to the audience which door they should use to reach the Toilets. This should be on with House Lights but be faded out when the toilets are closed prior to curtain up.

| House Light Areas | | Dimmer | DMX (Universe 1) |
|-------------------|-------------------------|--------|------------------|
| AUD | Foyer and rear seating | 1 | 501 |
| STG | Over stage | 2 | 502 |
| LOO | Socket for Toilets sign | 3 | 503 |
| B/S | Backstage corridor | 4 | 504 |

Control Panel Programs

| | | |
|---|---------|--|
| 1 | ON | All House Lights on at approximately 75% including Toilets sign. |
| 2 | LOO OFF | As 1 but without Toilets sign. Use this program for day-to-day use with no audience. |
| 3 | 50% | approximately half light |
| 4 | 25% | approximately quarter light |
| ☼ | ALL ON | All House Lights full on |
| ● | ALL OFF | All House Lights off |

Note that the highest value from either the control panel or the lighting desk will take precedence.

- When controlling from the desk, the control panel should be at ALL OFF. So before opening the house set House Lights levels from the desk then set panel to ALL OFF.
- When the desk is off, use the panel programs. So before shutting down the desk, set the panel to ON or ALL ON.

A diagram located by each control panel provides guidance. A copy is available on DropBox [here](#).

The House Light dimmer should remain powered on at all times. It is integrated with emergency lighting.

Bar Sign

The illuminated bar sign is controlled via a 4-channel DMX LED RGBW controller on DMX Universe 1, starting address 506. The sign should be illuminated when the bar is open, and faded out when it closes prior to curtain up.

Working Lights

Our main working lights in the auditorium are LED floodlights operated by two-way switches in the Control Box and Box Office.

There are blue LED working lights in the backstage corridor, controlled by a standalone dimmer at stage right. There is an LED working light for the backstage stage managers position, with an adjacent switch.

The sub-basement working lights are controlled by a switch at the top of the stairs. The top of stairs lighting can be switched between white LED strip light and blue LEDs using switches alongside.

Desk Lamps

There are a number of desk lamps for use backstage, fitted with blue LED bulbs such that they do not need to be covered in blue gel.

Emergency Lights

There is full cover of maintained and non-maintained LED emergency lighting and illuminated exit signage. These are regularly tested. These lights must not be obscured or disabled; however, we may be able to reduce the brightness of some maintained lights in certain circumstances with prior approval.

Projector

The projector is permanently fitted in a cradle and is typically mounted in the Grid as required. The projector is stored in the Tech Store, and the remote and video cables are kept in the Control Box. We do not have a screen as projection is usually onto part of the set. Check the remote battery and replace as required. Clean the projector filter regularly to prevent overheating and unexpected shutdown. Hard power is typically connected to the projector via the lighting patch. The projector should be shutdown using the remote before removing power. The projector should be derigged during your final get-out and all items returned to the correct store.

CCTV

There are two CCTV cameras covering the stage and the backstage corridor, working in all lighting conditions (colour in good light, monochrome in low light).

A control unit in the Control Box allows the operating technician to select one or other or both camera images in a range of variations on a display monitor in the Control Box. This display is replicated to monitors in the backstage corridor and the Stage Managers Room. The backstage corridor monitor can also directly select the backstage corridor camera – useful for checking that the audience is clear of the corridor.

Note that the monitor in the Stage Managers Room can be relocated by arrangement with us to the sub-basement corridor should the room be re-designated as a dressing room.

There is a separate security CCTV system with recording controlled by the Office.

Use of Smoke or Haze

If you wish to use smoke or haze you must agree this with us in advance, and all equipment must have a valid safety test. It may be necessary to arrange for fire alarm smoke detectors (located FoH and backstage) to be isolated by Front of House during its use, and for this to be incorporated into the production pre-show and post-show checklists.

Air Conditioning

Due to the environmental conditions in the theatre, air-conditioning must be on for all performances. Air comes from outside and is not recirculated, so complies with COVID regulations. We can adjust the settings to suit the circumstances.

There are three a/c units, operated using the control panels in the Control Box, and situated above the grid:

1. Stage right.
2. Centre.
3. Stage left.

Each unit can be turned on or off at the control panel. Do not alter any settings without checking with us first.

Network

Refer to the **diagram** in the Control Box or on Dropbox [here](#).

Internet

For access to external internet connectivity please contact us.

Main Network

There is a high-speed fibre optic internet link, accessible via a network router in the Box Office. This router offers Wi-Fi and physical connectivity.

The Wi-Fi SID, passwords and address allocations are available to authorised users.

The internal network – see below – can be connected to this network for internet access, with prior arrangement.

Tech Network

There is an internal network for technical use only, provided by a router in the Control Box, with 4 port ethernet switch and Wi-Fi. It does not have direct internet access, but its uplink can be connected to the main network for internet access, with prior arrangement.

The Wi-Fi SID, passwords and address allocations are available to authorised users.

The default router/gateway IP address is xx.xx.2.254, and it allocates IP addresses via DHCP in the same subnet with mask 255.255.255.0.

When adding devices to the network, configure them to obtain IP addresses automatically via DHCP from the router. No other device should be providing a DHCP service (including the lighting desk).

The following devices are normally connected to the network and allocated fixed IP addresses via DHCP:

- | | | | |
|---------------------|----------------------------|--------------|--------------|
| • Mac Mini | by ethernet cable | JST-MAC | xx.xx.xx.70 |
| • Mac Mini | by Wi-Fi | JST-MAC-WIFI | xx.xx.xx.71 |
| • ION Lighting desk | by ethernet cable (port 2) | JST-IONXE | xx.xx.xx.100 |

The default configuration allocates long leases for IP addresses, so devices should be allocated same address over a production run.

Do not update software or reconfigure the network unless absolutely necessary and only with our permission. Any changes must be documented and displayed in the Control Box, then reverted to default at your final get-out.

Trouble shooting connectivity:

- Check router is on and set to default settings as above.
- Check devices are connected by cable to the router port or by Wi-Fi on the correct SID as above.
- Devices should connect using DHCP to obtain valid IP addresses on the default subnet as above.
- The Mac and Lighting desk should be set to the default settings as above.
- Use device settings apps to check the connections and PING or other network tools to check connectivity.
- Note that the ION Lighting desk has two ports, which can be configured separately.
- The ION must be in normal operating mode (not settings) to accept connections.

Power

There is a 3-phase power supply to the building – see Appendix 1 – Power Distribution for more details. **Please be aware that there can be 415v between nearby sockets, including lighting sockets depending on how the lighting patch is configured.**

On Stage Power

There are no 13A sockets available backstage for on-stage power, other than in the Dimmer Room and Piano Store.

For on-stage lighting, use the lighting patch to provide dimmed or hard power from the Dimmer Room to the 15A sockets backstage, adjacent to each door.

For on-stage sound/video (only) there is a twin 13A socket adjacent to the Control Box.

On the walls of the Auditorium seating area, there is one twin 13A socket under seat E1, a 13A twin and a single 16A socket under seat E12, and a single 13A socket under seat G3. However, running of cables from here must not introduce risks for the audience. Typically, these sockets can be used for video equipment recording a show or rehearsal.

The Control Box has a range of 13A sockets and a single 16A socket.

Bring extensions and multiway adaptors for any equipment you bring.

Production Desks

There are two production desks, each 5ft x 3ft, with a range of removable scaff legs to suit different positions in the seat rake, spanning seat backs between two rows.

For pre-show production week, they are typically located in row D and C. For video streaming, desks are typically situated in row E and D. The seating capacity will be reduced accordingly.

Multiway power distribution units (one per desk) can be fed from On Stage Power locations. Signal cables can be run from the Control Box.

Sound

We have a standard default sound configuration as described below. Refer also to the indicated **diagrams**.

If agreed in advance with us, you may re-configure the system to suit your show. If you wish to bring your own or hired equipment you must agree this with us in advance, and all equipment must have a valid safety test.

Be aware that at your get-in the previous show may left the system in an unknown configuration so you are advised to check and reset the system configuration as necessary. In particular check the QLab and Mixer configurations and patching.

Main shows will have priority on sound configuration. **Ad-hoc events** during a show run will have to preserve the configuration fixed for the current show.

However, do not move the fixed speakers, nor any cables in trunking or fixed with cable ties without our prior permission. These are part of our standard rig. You can re-patch or reroute at the patch panels. Do not cut, modify or otherwise alter cables, connectors etc.

Racked or fixed-installation equipment should not be removed nor relocated to any production desk.

Please save your sound configuration as other users may use the system between your sessions and you may have to reset the system. Leave a diagram/description of your show's configuration in the Control Box.

Note that sound may be subject to interference from mobile phones so ensure these are off. Radio mics may also be subject to local radio interference.

You must return sound (including patching and speakers) to the default configuration at your final get-out.

Playback: Mac Mini, QLab, Yamaha Mixer

Audio playback is primarily from QLab on the Mac Mini to the Yamaha mixer, which also has inputs for mics, CD and mini-jack sources. The mixer also provides a MIDI interface for the Mac and QLab.

The Mac Mini is fitted into the Control Room rack. The Mac power switch is accessible in the front of the rack.

Mac Mini audio is connected to the Yamaha mixer via USB (digital audio and MIDI) and the patch panel (analogue).

Other Mac USB ports are extended to the desk level for keyboard and mouse.

The mixer is secured by "Kensington" cable locks in the Control Box. If it is necessary to relocate the mixer to a production desk, you will need to unlock and resecure to the production desk. Codes are available to authorised users.

Passwords are available to authorised users.

If you cannot use the default QLab/Mixer configuration, you should create and load your own QLab files and Mixer configurations required for your show, making sure you keep backups.

Sound Default Configuration

The default overall sound set up is as follows (refer also to the **diagrams**):

- QLab audio output channels send to Mixer channels via USB.
- Audio patch panel sends Mixer outputs Stereo Left and Right to Main powered Speakers Left & Right respectively, via Ties (Line circuits 1 and 2).*
- Audio patch panel sends Mixer outputs Omni 1 thru 4 to Amps 3 thru 6 respectively*.
- Audio patch panel sends Mac Mini built-in output (R mono) to Foyer sound system*.

*The default patch panel set up is with all cables removed.

The default Mixer set up is:

- QLab channels 1 & 2 patched to Mixer channels 1 & 2, routed to Stereo Left and Right.
- QLab channels 1 through 6 patched to Mixer channels 17 thru 22, routed to outputs L, R, Omni 1 thru 4.
- CD source connected to Mixer via analogue channels, routed to Stereo Left and Right.
- Aux 3.5mm jack sources connected to Mixer via analogue channels, routed to Stereo Left and Right.

The default speaker set up on the speaker patch panel (see below) is:

- Amp 1 to (Yellow) Speaker Tie (circuit 2) in Control Room
- Amp 2 to (Orange) Speaker Tie (circuit 4) in Control Room
- Amp 3 to Bass bin
- Amp 4 to Rear Left Surround
- Amp 5 to Rear Centre Left, Centre Right and Right Surrounds

- Amp 6 to Left, Centre Left, Centre Right and Right Fills

Sound levels are set as follows:

- All Amps have gain controls set at maximum.
- QLab cue levels are set to achieve desired output levels.
- Mixer channel gain is set to achieve desired output levels when channel and master faders are at 0dB.

Left and Right for stereo are oriented from the audience perspective – i.e. Stage Left is audience Right.

There are **diagrams** and **photographs of the default configuration** patch connections on Dropbox [here](#).

There are default Yamaha Mixer (Studio Manager) configurations, and QLab workspaces, available on the Mac Mini for use to reset to the default configuration, or as a starter for your own custom configurations.

Audio Patch

There is an audio patch bay in the Control Room rack which can be used to (re)route audio between the various pieces of equipment:

- Mixer
- Mac Mini
- Effects (FX) unit
- Amps
- Powered Main speakers
- Foyer sound system
- Show relay system

The default set up (see above) is with no patch leads installed.

Refer to the **diagram** in the Control Box for other options or on Dropbox [here](#).

The audio patch panel makes audio inputs and outputs available in one place, avoiding the need to remove equipment from, or get around the back of, the rack. This also reduces wear and tear on fixed cabling and terminations. It should be possible to do pretty much everything needed to re-patch sound using the patch panel, which is effectively self-documenting.

Through ‘normalisation’ default connections are made for the commonly used/standard setups. Different connections can be made by plugging patch cables between the appropriate patch sockets. This will disconnect the normalised connections if necessary.

By referring to the diagrams you can see which socket goes where and what the ‘normal’ connections are. There are some spare connections (e.g. for use for connecting additional equipment or to the tie lines), or connections can be made to those directly from the panel itself. Any cables present indicate where re-patching has been done. This approach enables an ad-hoc show to understand any changes made and temporarily revert any connections if necessary, reinstating them afterwards. It also makes resetting the system at get-out or subsequent get-in much easier.

Please ensure that any routing and connections done at get-in use the patch panel as much as possible, rather than unplugging equipment or running extra cables, and that any changes are recorded. Then please ensure it’s all reset at get-out, including any ‘behind the scenes’ changes – colour-coding, labels and photos show how things should be connected in the rack.

Note: The patch and wiring are set up for balanced signals (unless indicated, e.g. from the Mac Mini built-in audio in/out) so use TRS connections in the patch panel. There are TRS patch cables and TRS-XLR cables available.

Speakers and Patch

There is a speaker patch behind the Control Room rack which can be used to (re)route the arrangement of speakers to amps. Colour-coded Speak-on fly leads connect to the patch panel for the speaker circuits and the Control Box Tie Lines (see below). Refer to the **diagram** in the Control Box or on Dropbox [here](#).

The following fixed speakers and circuits are installed. Others can potentially be added.

- Main Left circuit (colour-code Black) – to speakon connector in Grid[^]
- Main Right circuit (Red) – to speakon connector in Grid[^]
- Bass Speaker (Silver) – EM150

- Overhead Fill Speakers
 - Left (White) – EM15 (a second parallel connection point is available)
 - Centre Left (Purple) – EM15
 - Centre Right (Blue) – EM15
 - Right (Green) – EM15 (a second parallel connection point is available)
- Rear Surround Speakers
 - Left (White) – JBL Control One
 - Centre Left (Purple) – JBL Control One
 - Centre Right (Blue) – JBL Control One
 - Right (Green) – JBL Control One

^ Note that our default Main speakers are powered and fed by line level signals through tie lines, so the Main speaker connections are not used in the default set up. Hard power for the Main speakers is provided from the Dimmer Room 13A supply via LX patch circuits.

The Main speakers are hung from the Grid and extension cables are available if they need to be relocated.

The Bass, Fill and Surround speakers are in fixed positions.

There should be no need to alter installed speaker cabling. The default set up is as above. See also Tie Lines below.

A number of additional speakers are available for show specific purposes.

Tie Lines

There are tie lines running from a panel in the Control Box to similar panels in the backstage corridor by each door to the stage (Stage Left and Stage Right).

The lines in the panels include XLR balanced audio for Mic (1 to 16) and Line signals (1 to 8), Speak-on speaker (1 to 4), and XLR Intercom connections (A and B.) Take care to only use the tie lines at the appropriate voltage/current rating to prevent damage. Some tie lines are permanently allocated to Main speakers, Show Relay, Paging Mic, and Intercom (see below).

Most tie lines run one-one between all panels. However, this is not the case for **speaker tie lines**. Control Box Speaker Tie 1 runs to Ties 1 & 2 in parallel on each other panel (labelled B/S A), and Control Box Tie 3 runs to Ties 3 & 4 in parallel on each other panel (labelled B/S B). Control Box Ties 2 & 4 run to fly leads at the speaker patch behind the Control Room rack.

DMX tie lines are separate – see DMX section above.

Show Relay & Paging

Audio from a mic over the stage is fed to a mixer/pre-amp (channel 1) in the Control Box rack. Paging mics in Control Box (channel 2) and Backstage corridor (via mic tie line 6 to channel 3) feed into the same mixer/pre-amp. ~~A line feed input (channel 6) is available on the Audio Patch for playback into show relay.~~ Other inputs are not used.

The mixed output (Main R) is sent via a tie line (circuit 6) to backstage SL then via a dedicated line to an amplifier in the sub-basement SM Room, feeding speakers (with volume controls) in each Dressing Room, SM Room, Corridor and Workshop. A separate mono summed output is available on the audio patch panel.

Typically show relay cables are colour coded Orange.

Make sure the show relay pre-amp in the Control Box rack is turned on, and the amplifier in the SM Room is turned on at wall and amp.

Levels on mixer/pre-amp, amplifier and speakers should be set during get-in using a logical gain structure, and parameters agreed for adjustment, if necessary, during the production. Levels can be set on the mixer/pre-amp inputs and outputs, on the show relay amplifier, and individual speakers. Brief actors on the need to keep individual speaker levels in their dressing rooms sufficient to ensure they hear their cues and calls.

Do not interfere with the mic and tie line patching for show relay. The mixer/pre-amp mic channels are set to Mic (not Line) level, and the playback feed to Line (not Mic) level on the rear panel and should not be changed. Phantom power is not used and should be off. The Mic Monitor switch on the front panel should be off.

Hearing Loop

The hearing loop installed in the auditorium (with an Ampetronic ILD9 hearing loop driver) is currently **out of order**. A headset receiver is available for testing the loop.

Intercom (Ring)

There is an intercom system with fixed TecPro stations in the Office (for Front of House) and sub-basement (for Backstage), and TecPro/ChromaQ belt-packs with headsets in the Control Box (for the operating technician) and backstage corridor (for stage management). There is a belt-pack situated outside the main auditorium door, typically for use as a cue light should there be entrances from there. Other locations can be set up if agreed in advance, and existing positions can be extended with standard 3-pin XLR cables.

Please do all you can to avoid damaging belt-packs and headsets through dropping them!

The system uses labelled tie lines and is powered from a TecPro PSU in the Control Box. It should come on with the Control Box equipment. Typically, intercom cables are colour coded Green/Yellow. Do not interfere with the tie line patching for the intercom.

Live Music

We recommend that vocalists bring their own preferred microphone and stand – ours are for general use and may not suit your performance. Any instruments requiring a feed to our PA system should bring their own DI boxes. We do not have any on-stage monitor speakers.

You should also bring your own music stands and lights, and if you need multiple power sockets bring multiway sockets to plug in to our on-stage 13A sound-only power supply, located adjacent to the Control Box.

Piano

If you wish to use our upright piano, please discuss with us in advance as access and on-stage positioning will be dependent on the set layout. It is tuned regularly, but special tuning can be arranged by agreement.

Foyer Sound System

There is a standalone sound system for background music in the Foyer operated by Front of House staff. This can play music from a local source (e.g. USB stick with MP3 tracks, or Bluetooth audio device) and/or receive show sound from the Control Box via a dedicated line from the Audio Patch (see above).

Video

We have recently acquired video production equipment for recording and streaming. Further details available on request.

Appendix 1 – Power Distribution

Office

Main Power (inside panel behind main desk)

- Theatre Busbar
- Unknown main switch
- Stage Lighting main switch
- Office light and power main switch
- Auditorium light and power
 - With Aircon Distribution Board – 3 circuits, one per aircon unit

Office Distribution Board (above filing cabinet) DB3

Main breaker [100A]

1. [32A] 3x Twin 13A sockets in Control Box and Twin 13A sockets at left rear of auditorium
2. [32A] Sockets in Office, Box Office, Bar
3. [32A] Fire Alarm (control panel in Foyer store)
4. [20A] Backstage Sockets inc. Piano Store and Water Heater
5. [10A] Lighting on Street Stairs and Outside
6. [10A] Lighting in Toilets (including emergency), Office and Workers in theatre

Control Box

Equipment Isolator fed from 32A breaker feeding to Equipment Breaker DB1

Main breaker [100A]

1. [32A] Twin 13A socket at right rear of Auditorium
2. [32A] Light & Sound Equipment rack and sockets
3. [16A] 16A socket at left rear of Auditorium
4. [16A] 16A socket in Control Box below DB1
5. [16A] Twin 13A sockets for stage sound only

Dimmer Room

Stage Lighting Distribution Board (3 Phase)

Main Breaker [100A 3 Phase]

1. [63A] Dimmer One – L1 Red phase
2. [63A] Dimmer Two – L2 Yellow phase
3. [63A] Dimmer Three – L3 Blue phase
4. [63A] Dimmer Four – L1 Red phase
5. [63A] Dimmer Five – L2 Yellow phase
6. [63A] Hard power (or Dimmer 6) – L3 Blue phase
7. [16A] Mains sockets to left of dimmers – L1 Red phase
8. [16A] Dimmer fan spur – L2 Yellow phase
9. [16A] Twin 13A and single 15A adjacent to DB – L3 Blue phase.

Auditorium House Lighting Isolator and House Lighting Dimmers & Breakers (L2 Yellow phase)

1. [10A] Foyer and over rear seating
2. [10A] Over stage
3. [10A] House socket to left of dimmers
4. [10A] Backstage corridor

Emergency Lighting Isolator EMG

[10A] Box Office lighting, Control Box lighting, Bar lighting, Emergency Maintained/Non-maintained Lighting

Dressing Room 2**Sub-basement DB2**

Main breaker [100A]

1. [6A] Corridor Lights incl. workshop
2. [16A] Not used
3. [32A] Not used
4. [6A] Office Lights – SM and Office

RCD [80A 30mA] for circuits below:

1. [32A] Dressing Room Power #2
2. [32A] Dressing Room Power #1
3. [16A] Office Power – SM and Office
4. [6A] Dressing Room Lights
5. [6A] Not used
6. [32A] Not used
7. [16A] Workshop Power
8. [16A] Not used

JST Tech Diagrams

For use in conjunction with
JST Tech Spec

Sound

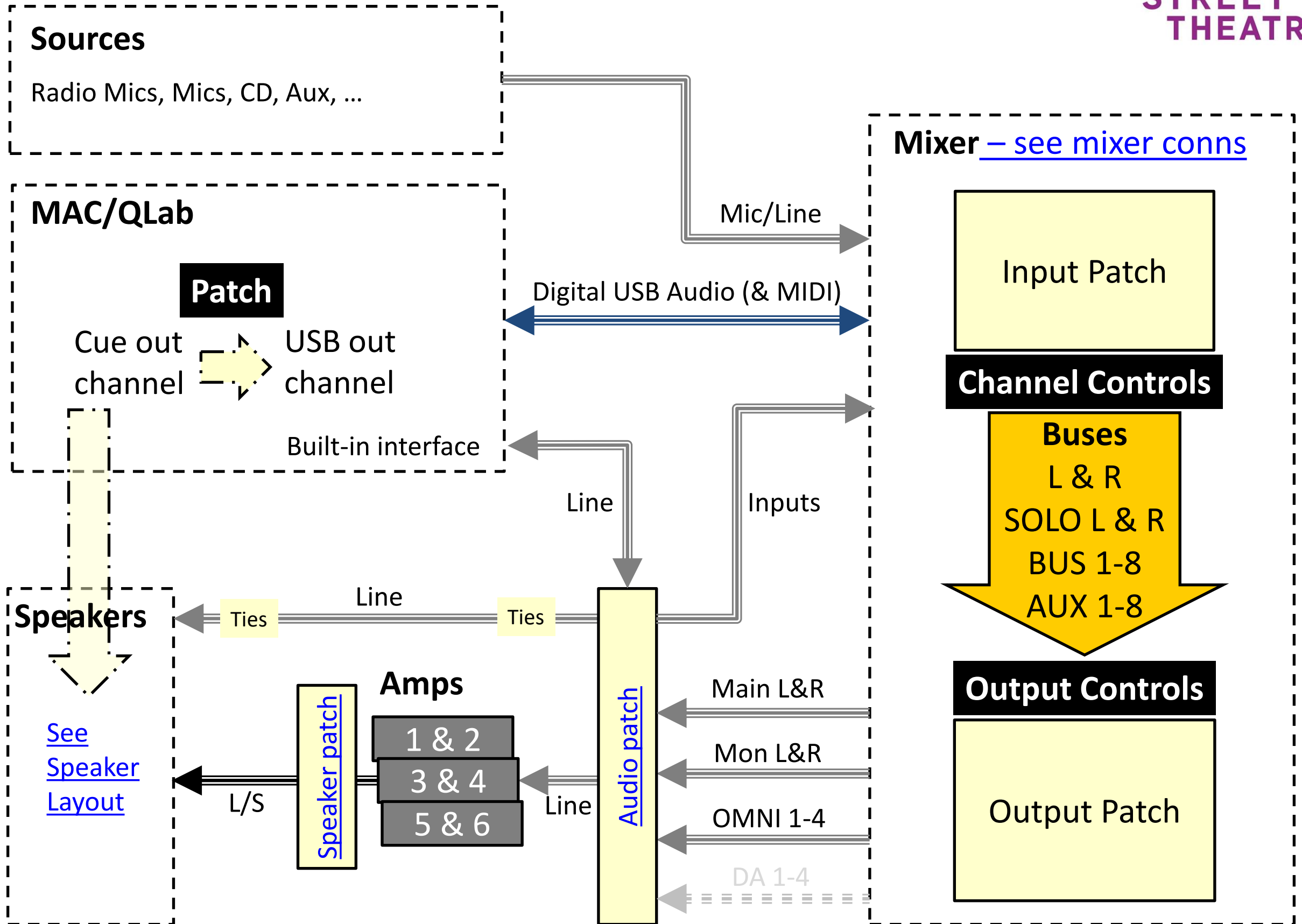

Sound Routing

Shows standard default setting

| Qlab | | Mixer Layer 1 | Mixer Layer 2 | Mixer Bus | Mixer Out | Audio Patch | Amp | Speaker Patch | Speakers |
|------|-----|---------------|---------------|-----------|-----------|-------------|-----|---------------|-------------|
| 1 | USB | 1 | 17 | L | L | | | | Main L |
| 2 | | 2 | 18 | R | R | | | | Main R |
| 3 | | | 19 | BUS 1 | OMNI 1 | | 3 | | Sub |
| 4 | | | 20 | BUS 2 | OMNI 2 | | 4 | | Rear L |
| 5 | | | 21 | BUS 3 | OMNI 3 | | 5 | | Rear Others |
| 6 | | | 22 | BUS 4 | OMNI 4 | | 6 | | Fills |

Notes

QLab audio patch 1-1 to USB to Yamaha Mixer

Mixer layer 1 for simple stereo shows; also has other inputs routed to L & R

Mixer layer 2 for full multi-channel shows, routed to all speakers

Main L & R speakers are powered and fed via tie lines

Amps 1 & 2 are available for additional speakers

Colours of labels correspond to cable loom connector colours

Mixer Connections

Shows standard default setting

Colours of connectors correspond to cable loom connector colours

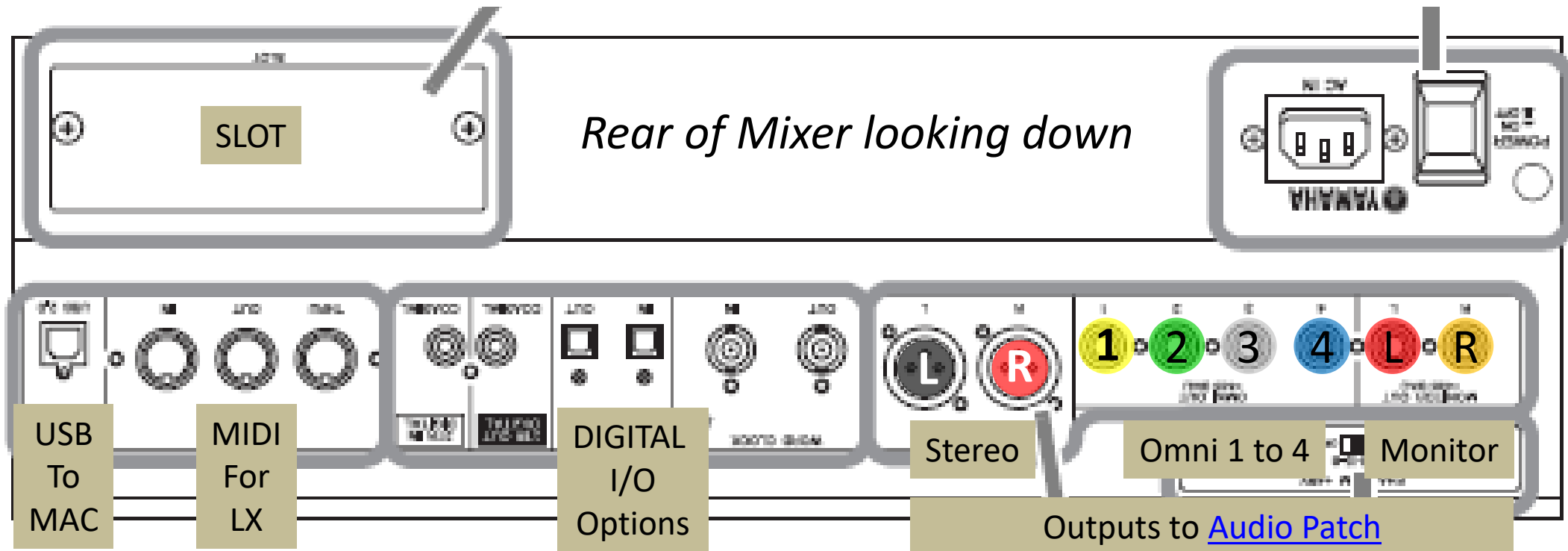

Inputs from [Audio Patch](#)

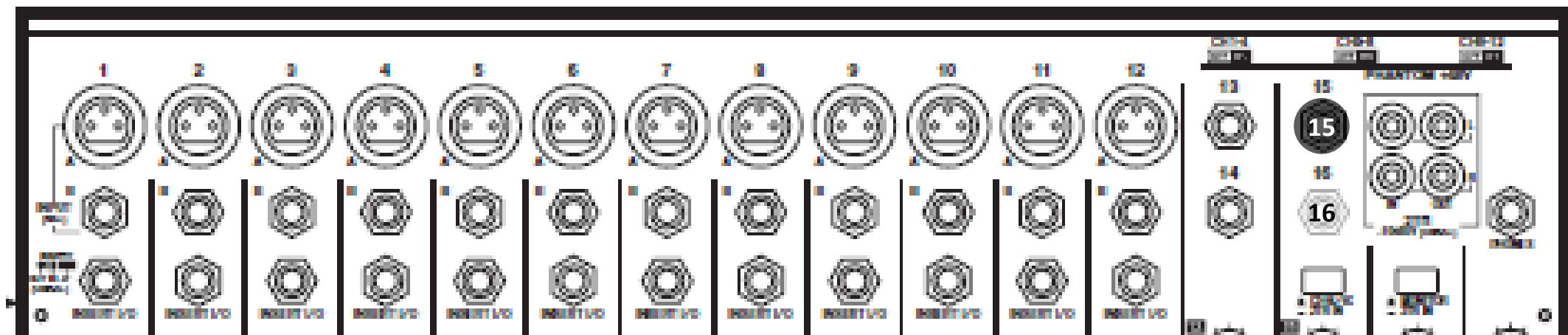

Speaker Layout

Shows standard default setting

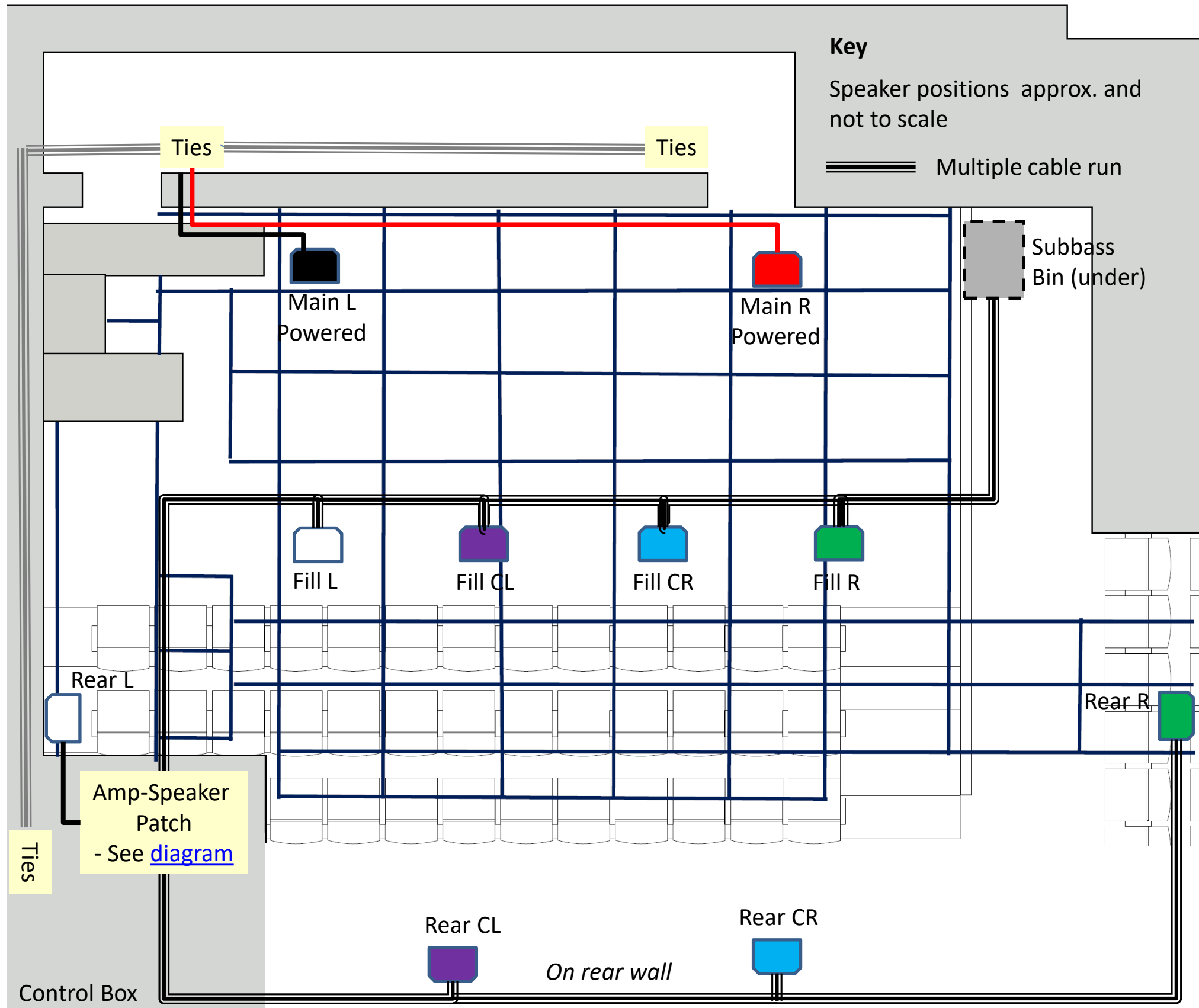

Refer to Tech Spec for more.

Audio Patch (in front of audio rack)

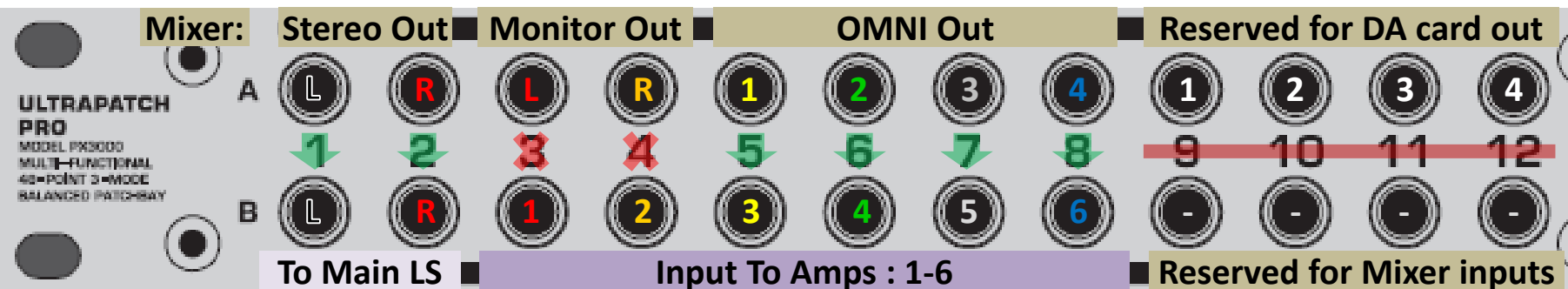

See Amp-Speaker Patch: Tie Tie Sub Rear L Rears Fills

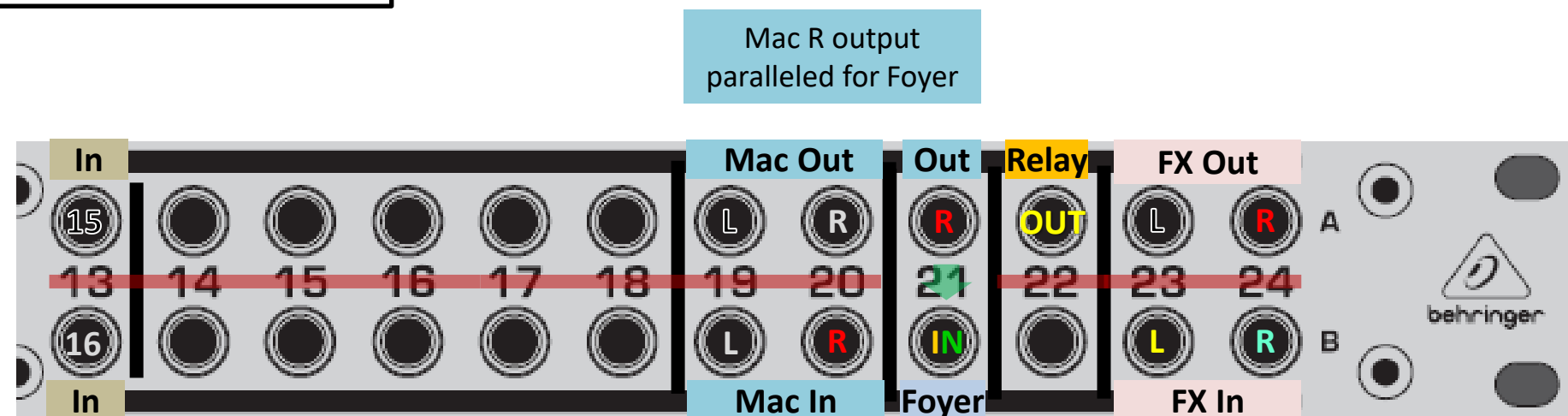

Standard default setting is with no patch cables in use. Use patch cables to alter connections.

- ➡ Connected by default – plugging in to connect to the circuit also disconnects the link
- ✗ NOT connected by default – add patch cable to link
- Separate circuits for individual use

Colours of connector labels correspond to internal cable loom connector colours

Amp-Speaker Patch (on rear of audio rack)

Shows standard default setting

Amplifier outputs

Speakon sockets wired in parallel by amplifier output
Only circuit pair 1 connected (1+ and 1-)

Refer to Tech Spec for more.

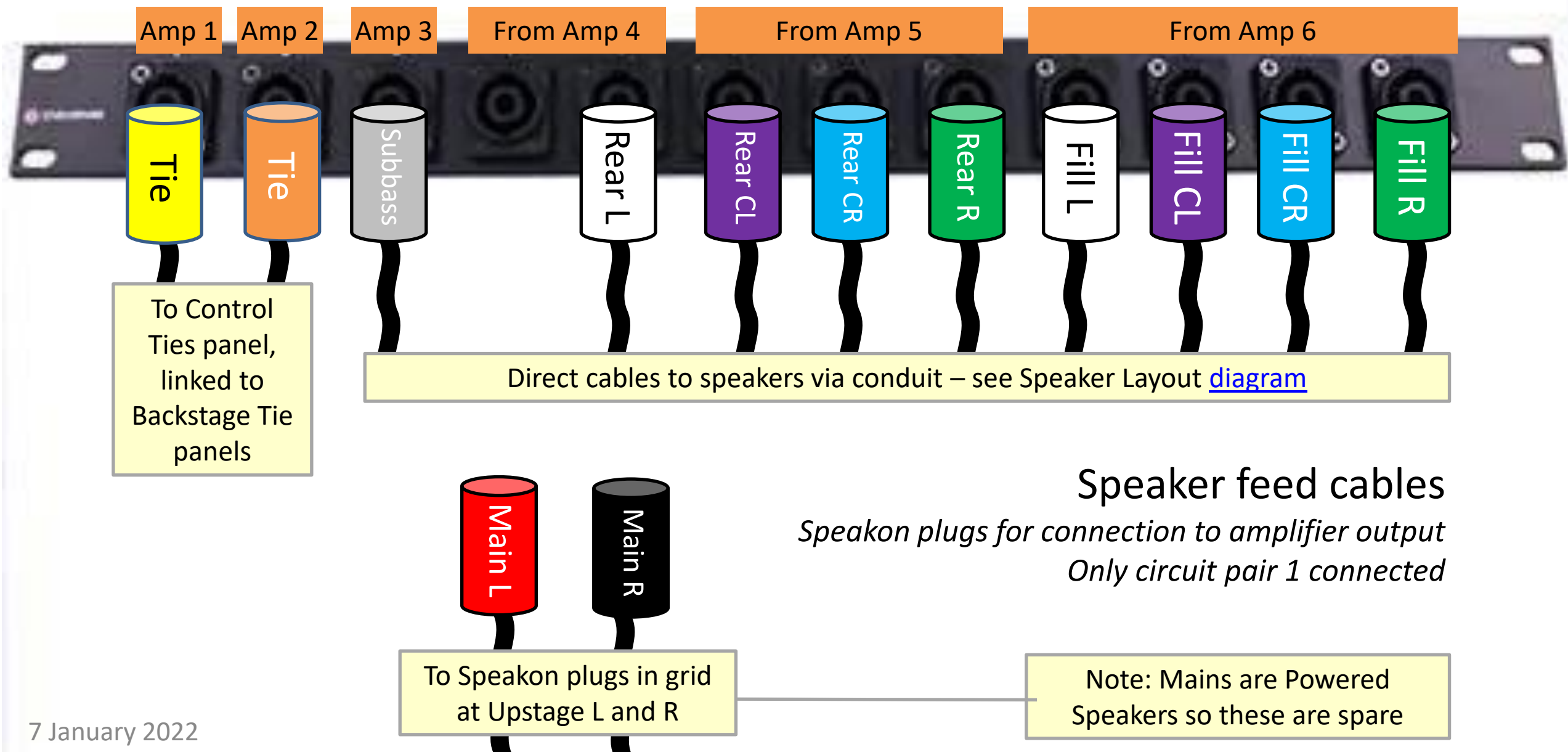

Lighting

Shows standard default setting

**JERMYN
STREET
THEATRE**

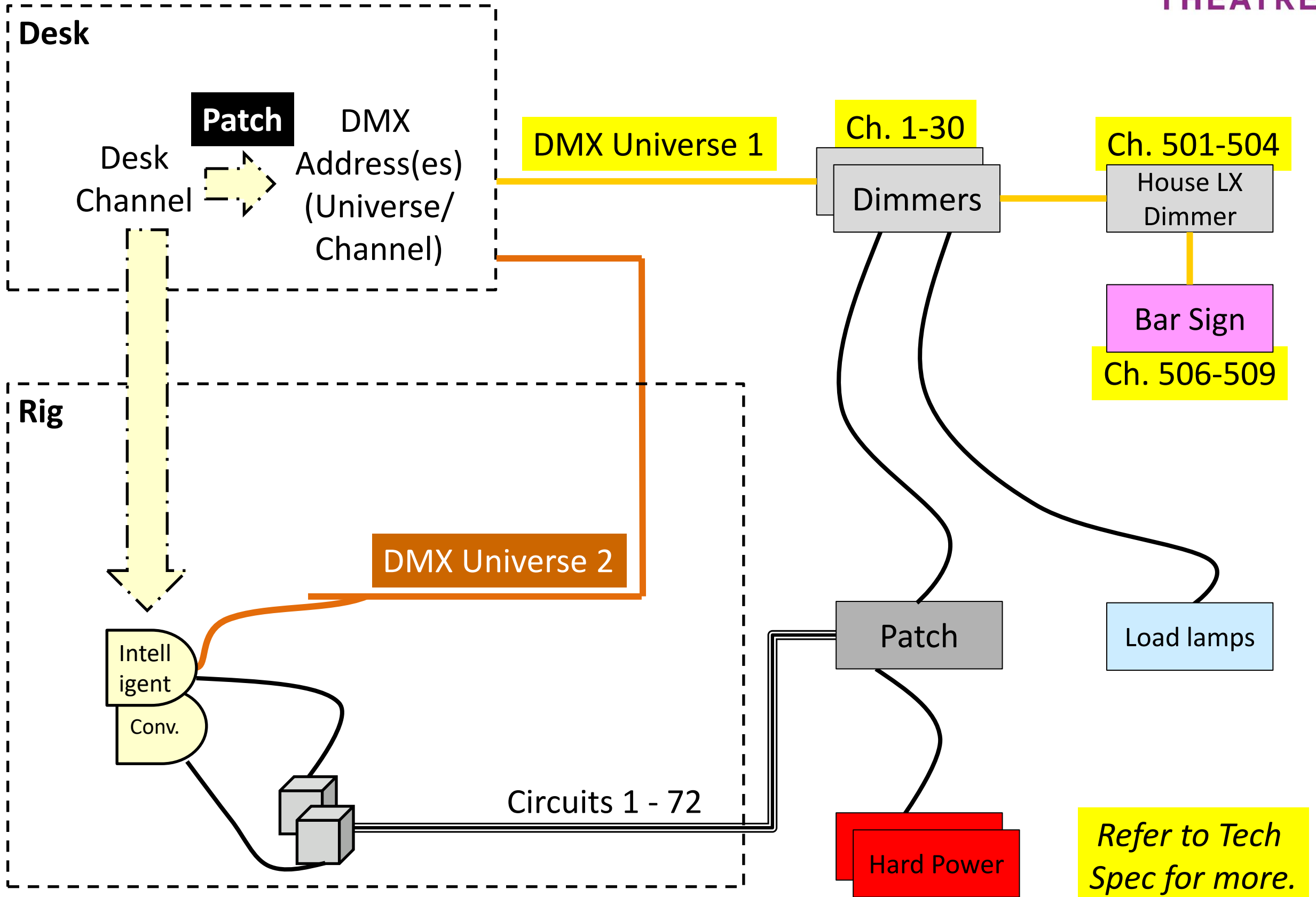

Networks

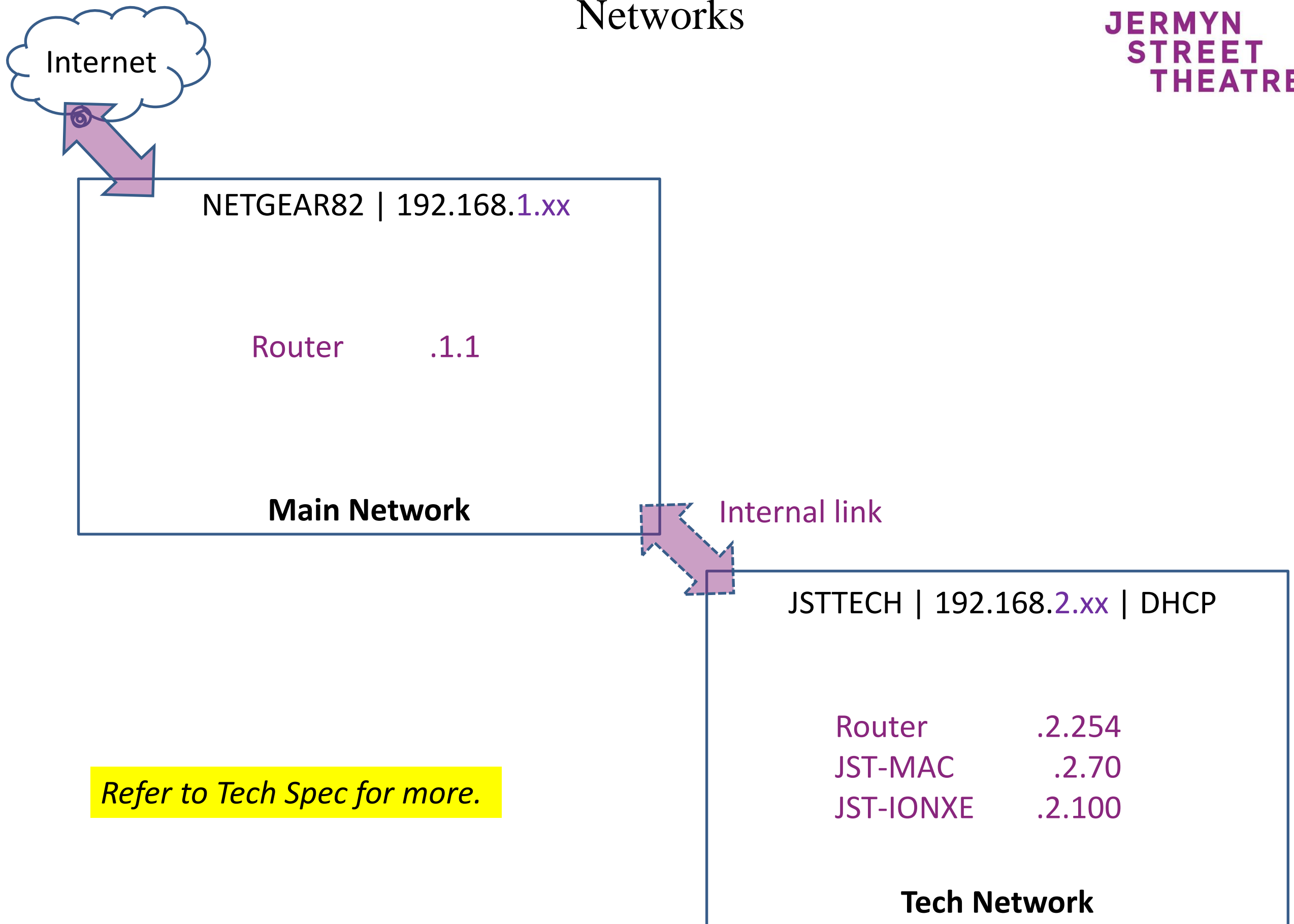

Refer to Tech Spec for more.